

Installation and maintenance instructions for PLATIN Rainwater Underground Tank

PLATIN

1500 L	Order No. 390000
3000 L	Order No. 390001
5000 L	Order No. 390002
7500 L	Order No. 390005



The points described in these instructions must be observed under all circumstances. All warranty rights are invalidated in the event of non-observance. Separate installation instructions are enclosed in the transportation packaging for all additional articles purchased from GRAF.

Missing instructions must be requested from us immediately.

The tank must be checked for any damage prior to insertion into the trench under all circumstances.

Missing instructions can be downloaded on www.graf.info or can be requested from GRAF.

Table of contents

1. GENERAL NOTES	13
1.1 Security	13
1.2 Identification obligation	13
2. INSTALLATION CONDITIONS	14
3. TECHNICAL DATA	15
3.1 Technical Data Platin	15
3.2 Overview tanks Platin	15
4. TANK STRUCTURE	16
5. INSTALLATION AND ASSEMBLY	16
5.1 Construction site	17
5.2 Trench	17
5.3 Insertion and filling	19
5.4 Routing connections	19
6. ASSEMBLING THE TELESCOPIC DOME SHAFT	20
6.1 Fitting telescopic dome shaft	20
6.2 Telescopic dome shaft (pedestrian loading)	20
6.3 Telescopic dome shaft (driven on by cars)	20
6.4 Universal telescopic dome shaft	20
7. ASSEMBLY OF THE ADAPTER	21
7.1 Assembling the extension	21
8. INSPECTION AND SERVICING	21

1. General notes

1.1 Security

The relevant accident prevention regulations according to BGV C22 must be observed during all work. Particularly when walking on the tanks, a 2nd person is required to secure the tank.

The relevant regulations and standards must additionally be taken into consideration during installation, assembly, servicing, repair, etc. Relevant notes can be found in the corresponding sections of these instructions.

During all work on the system or parts of the system, the entire system must always be rendered inoperable and secured to prevent unauthorised reactivation.

Except in the event of work carried out in the tank, the cover of the tank must always be kept sealed, as this otherwise constitutes a maximum risk of accident. The rain protection installed on delivery is merely transportation packaging. It cannot be walked on and is not child-proof; it must be replaced with a suitable cover immediately following delivery (telescopic dome shaft with corresponding cover)!

Only original GRAF covers or covers approved in writing by GRAF must be used.

GRAF offers an extensive range of accessories, all of which are designed to match each other and which can be extended to form complete systems. The use of accessories that have not been approved by GRAF results in the exclusion of the warranty/guarantee.

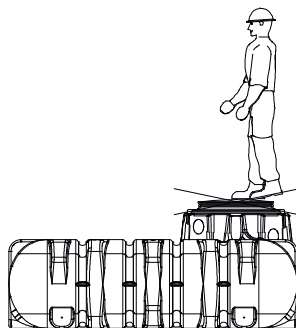

1.2 Identification obligation

All service water pipes and outlets must be identified in writing with the words "**Not drinking water**" or in the form of images (DIN 1988 Part 2, Para. 3.3.2.) in order to avoid inadvertent connection with the drinking water mains even after a number of years. Mix-ups, e.g. by children, may still occur even in the case of correct identification. All service water extraction points must therefore be installed with valves with **child-proof locks**.

2. Installation conditions

Coverage heights with telescopic dome shaft in green areas.

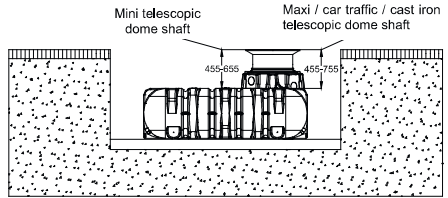

Maximum coverage heights with extension and telescopic dome shaft.

(in green areas only – not under passable areas)

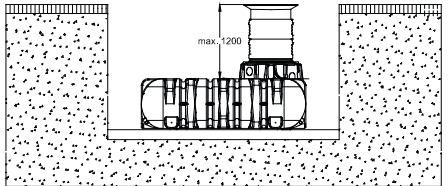

Cover heights with telescopic dome shaft car traffic / telescopic dome shaft cast iron in areas with car traffic (load up to 3.5 tonnes).

(without groundwater and stratum water)

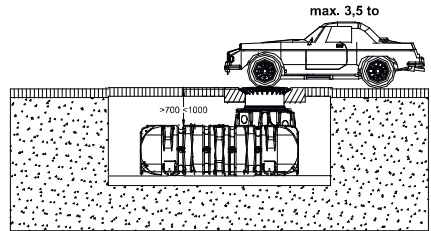

Cover heights with cast or HGV-bearing telescopic dome shaft

(with cover class B or D – provided by customer), in area driven over by HGVs.

(without groundwater and stratum water)

Please note: HGV can only be driven over if a self-supporting, (Steel)-reinforced concrete plate is installed

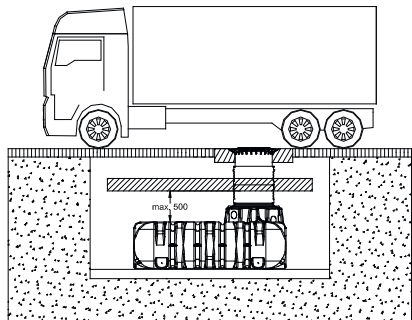

Coverage heights on installation in groundwater – the hatched area specifies the permissible immersion depth for the tank.

(not under passable areas)

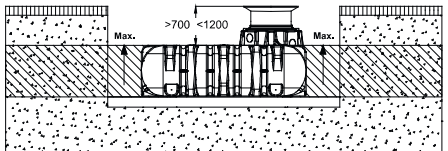

3. Technical data

3.1 Technical Data Platin

(1500 L, 3000 L, 5000 L, 7500 L)

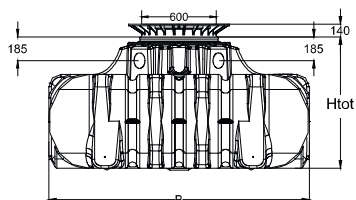
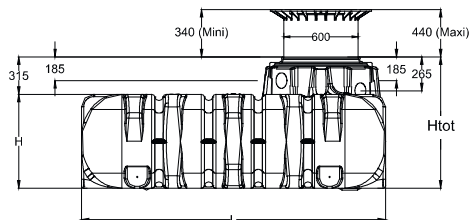

3.2 Overview tanks Platin

Tank	1500 L	3000 L	5000 L	7500 L
Art. No.	390000	390001	390002	390005
Weight	82 kg	180 kg	250 kg	380 kg
L	2100 mm	2450 mm	2890 mm	3600 mm
W	1250 mm	2100 mm	2300 mm	2250 mm
¹ H	700 mm	735 mm	1000 mm	1250 mm
² H _{tot}	1015 mm	1050 mm	1315 mm	1565 mm

¹ H = High tank container

² H_{tot} = High upper edge tank dome

4. Tank structure

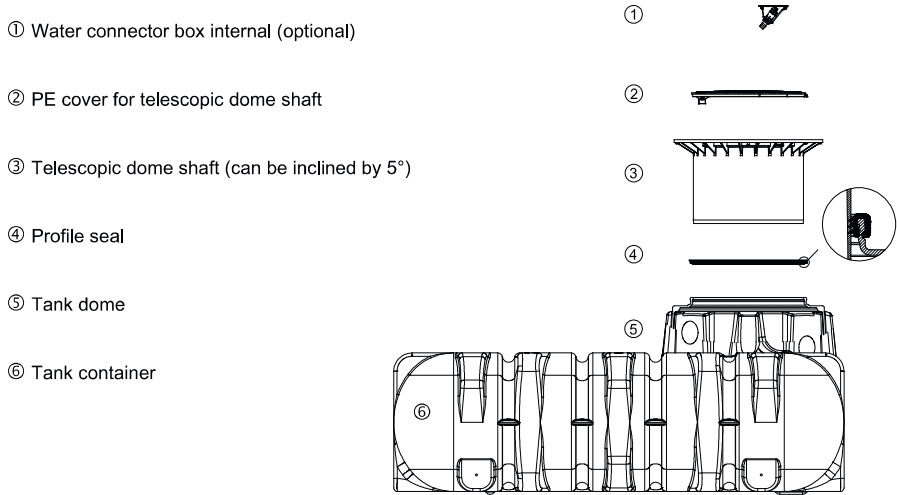

5. Installation and assembly

- ① Subsoil
 - ② Telescopic dome shaft
 - ③ Compacted foundation
 - ④ Surrounding (round-grained gravel, max. grain size 8/16)
 - ⑤ Covering layer
 - ⑥ PLATIN Rainwater Underground Tank
 - ⑦ Concrete layer for passable surfaces
- β** --> DIN 4124 from 1250 mm depth of the trench

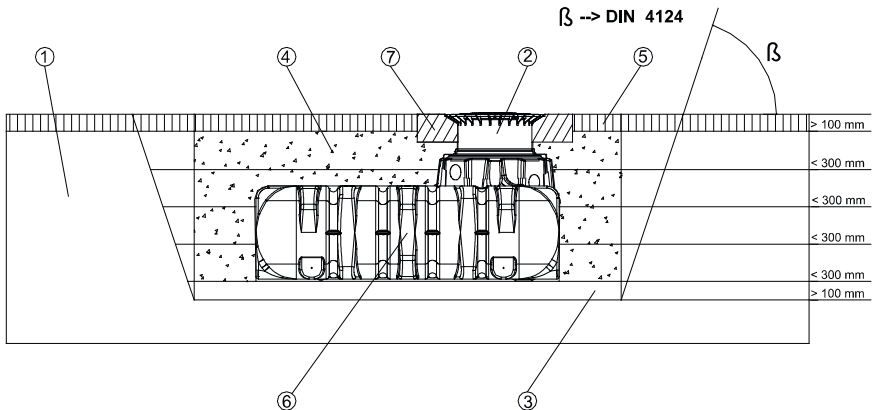

5. Installation and assembly

5.1 Construction site

Under all circumstances, the following points must be clarified prior to installation:

- The structural suitability of the ground according to DIN 18196
- Maximum groundwater levels which occur and drainage capability of the subsoil
- Types of load which occur, e.g. traffic loads
- **Please note:** HGV can only be driven over if a self-supporting, steel-reinforced concrete plate is installed!

An expert ground report should be requested from the local planning authority to determine the physical characteristics of the subsoil.

5.2 Trench

To ensure that sufficient space is available for working, the base area of the trench must exceed the dimensions of the tank by > 100 mm on each side; the distance from solid constructions must be at least 1000 mm.

If the depth of the trench is > 1250 mm an embankment must be designed according to DIN 4124. The construction site must be horizontal and plane and must guarantee sufficient load-bearing capacity.

The depth of the trench must be dimensioned so that the max. earth coverage (see point 2 – installation conditions) above the tank is not exceeded. To use the system throughout the entire year, it is necessary to install the tank and those parts of the system which conduct water in the frost-free area. The frost-free depth is usually approx. 600 mm – 800 mm; precise information in this regard can be obtained from the responsible authority.

A layer of compacted, round-grain gravel (grain size 8/16, thickness approx. 100 - 150 mm) is applied as the foundation.

5.2.1 Slope, embankment, etc.

On installation of the tank in the immediate vicinity (< 5 m) of a slope, earthen mound or slope, a statically calculated supporting wall must be erected to absorb the soil pressure. The wall must exceed the dimensions of the tank by at least 500 mm in all directions, and must be located at least 1000 mm away from the tank.

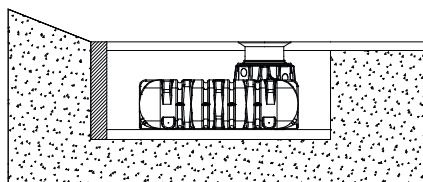

5.2.2 Groundwater and cohesive (water-impermeable) soils (e.g. clay soil)

If it is anticipated that the tanks will be immersed deeper into the groundwater than is shown in the adjacent figure, sufficient dissipation must be ensured. (See table for max. immersion depth).

Dissipation of the drainage water (e.g. via an annular drainage system) is recommended in the case of cohesive, water-impermeable soils.

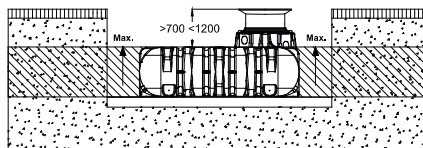

Tank	1500 L	3000 L	5000 L	7500 L
max. immersion depth	700 mm	735 mm	1000 mm	1250 mm

5. Installation and assembly

5.2.3 Installation below HGV-bearing surfaces

The shaft can only be driven over with HGV in conjunction with a self-supporting, iron-reinforced concrete plate. To ensure that no additional forces or effects of HGV-bearing are transferred to the tanks, the dimensions and strength of the concrete plate must be statically calculated.

If you have any questions in this regard, please contact your GRAF-Team.

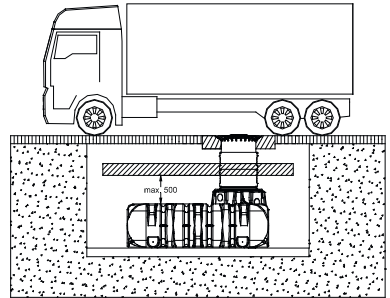

5.2.4 Installation adjacent to surfaces used by vehicles

If the underground tanks are installed adjacent to surfaces which are used by heavy vehicles weighing over 3,5 t, the minimum distance away from these surfaces is at least the depth of the trench.

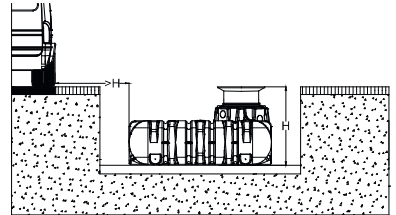

5.2.5 Connection of several tanks

Two or more tanks are connected via the assembly surfaces by means of GRAF special seals and basic pipes (to be provided at construction site).

The apertures must be drilled to the corresponding size using only the GRAF special crown bit. It must be ensured that the distance between the tanks is at least 500 mm. The pipes must project at least 50 mm into the tanks.

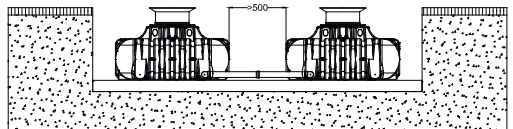

5. Installation and assembly

5.3 Insertion and filling

The tanks must be inserted, impact-free, into the prepared trench using suitable equipment. To avoid deformities, the tank is filled 1/3 with water before filling in the tank surrounding.

Afterwards the surrounding (roundgrain gravel, max. grain size 8/ 16) is then filled in layers of max. 30 cm steps and is compacted.

The individual layers as well as the medial support column must be well-compacted (manuel tamper). Damage to the tank must be avoided during compaction. Mechanical compaction machines must not be used under any circumstances. The surrounding towards the trench must be at least 100 mm wide.

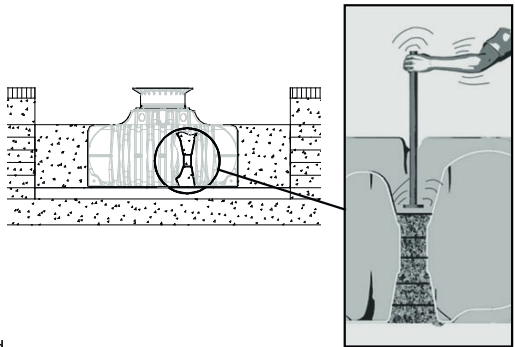
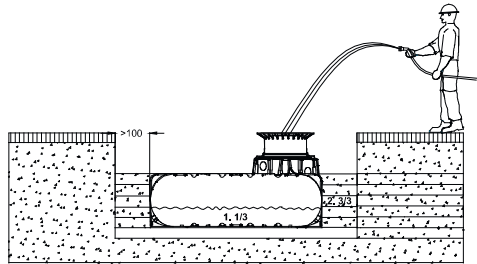

5.4 Routing connections

All feed and overflow pipes must be routed with a decline of at least 1 % in the direction of flow (possible, subsequent settling must be taken into consideration in this case). If the tank overflow is connected to a public sewer, this must be protected against reflux by means of a lifting station (mixed sewer) or reflux seal (pure rainwater sewer) according to DIN 1986.

All suction, pressure and control lines must be routed in an empty pipe, which must be routed as straight as possible, without bending, to the tank with a decline. Necessary bends must be formed using 30° moulded sections.

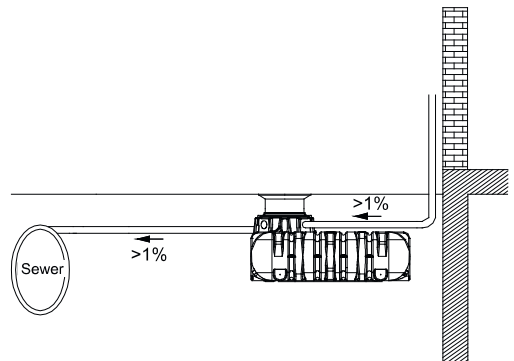

Important: The empty pipe must be connected to an aperture **above** the max. water level.

6. Assembling the telescopic dome shaft

6.1 Fitting telescopic dome shaft

The telescopic dome shaft allows the tank to be variably adjusted to the given ground surface. For assembly, the profile seal (EPDM material) of the tank dome is generously rubbed with soft soap (do not use mineral oil-based lubricants, as these attack the seal). The telescope is then also greased, inserted and levelled to the ground surface.

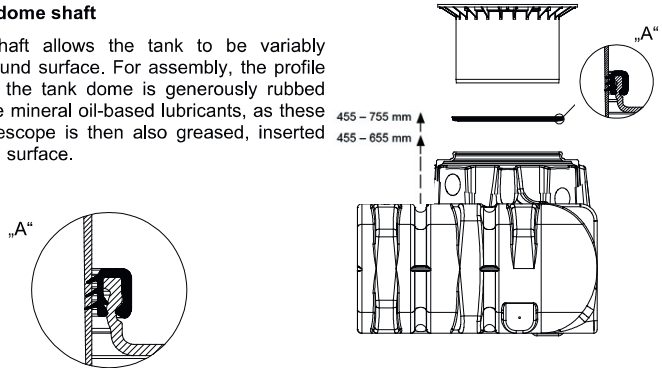

6.2 Telescopic dome shaft (pedestrian loading)

To prevent loads from being transferred to the tank, the telescope ① is filled in layers (< 300 mm) with round grain gravel ② (max. grain size 8/16) and compacted evenly. Damage to the container tank dome ③ or telescope must be avoided. Then place the manhole cover in position, screw the cover lock shut with a hexagon spanner and tighten it so that it cannot be opened without tools.

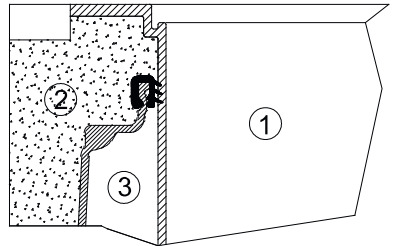

6.3 Telescopic dome shaft (driven on by cars)

If the container is installed under car traffic areas, the telescope ① must be underlaid with concrete ④ (load class B25 = 250 kg/m²) in the collar area. The concrete layer to be filled must be at least 300 mm wide and approx. 200 mm high all round.

Only for telescopic manhole for cars: Close the manhole cover with a hexagon spanner and tighten it so that it cannot be opened without tools.

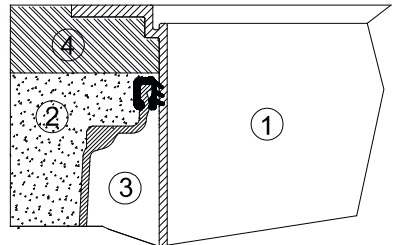

6.4 Universal telescopic dome shaft

For installation under lorry traffic areas, the telescope ① is shimmed as described in point 6.3 above. The cast frame ⑤ to be provided by the customer or the concrete rings ⑥ to be provided by the customer are then installed to distribute the load on the cover. The cast frame must have a bearing surface of approx. 1 m² so that the load forces cannot be transferred to the manhole casing ③ under any circumstances.

Attention: It is essential to use a class D cover.

