

ECOBLOC SMART INFILTRATION

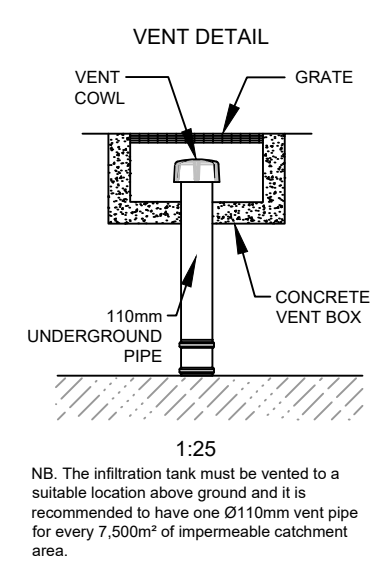
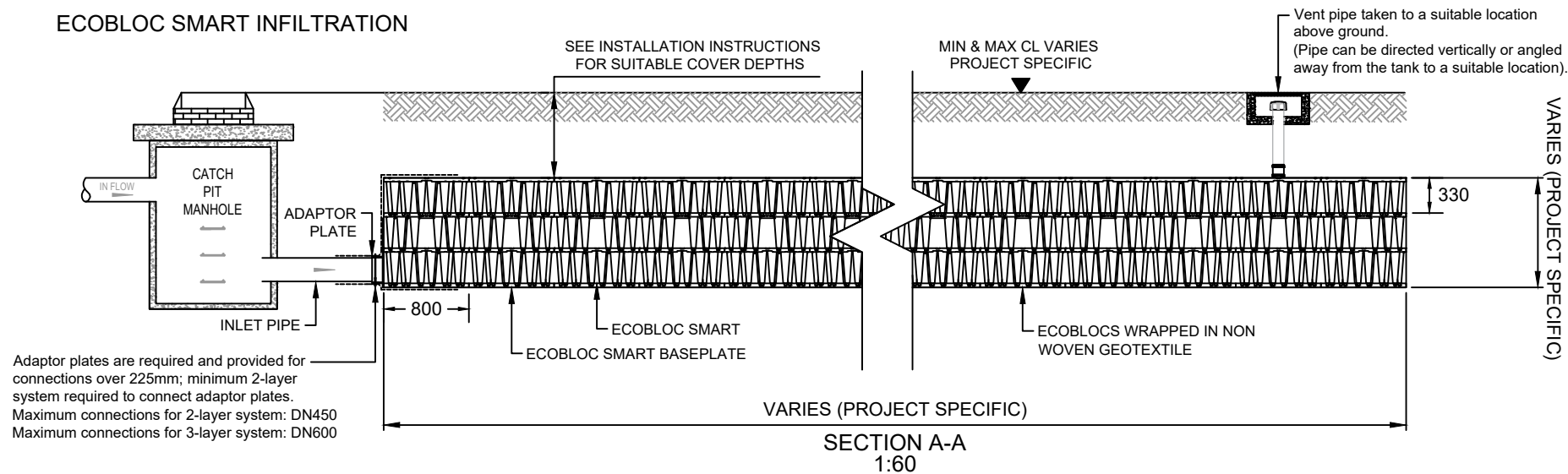

THIS DOCUMENT IS SUPPLIED IN STRICT CONFIDENCE AND MUST NOT BE LENT, REPRODUCED OR DISCLOSED TO ANY THIRD PARTY WITHOUT THE WRITTEN CONSENT OF GRAF AUSTRALIA PTY LTD

DO NOT SCALE - IF IN DOUBT ASK

Notice: This drawing is issued only as a guideline and is an estimate of the materials required to construct the drainage system, it should not be used for construction purposes.
Graf Australia Pty Ltd makes no warranty or guarantee in relation to the suitability of any of the layout details shown on this drawing in relation to a particular scheme.

- NOTES:-
- All dimensions in mm, unless otherwise stated.
 - All dimensions are nominal and may vary within manufacturing tolerances.
 - All site temporary enabling works by others.
 - Graf products to be installed in strict accordance with Graf installation instructions.
 - This drawing is intended for guidance only. Confirmation of the suitability for a particular project should be sought from the consulting engineers prior to final design or commencement of any construction works.

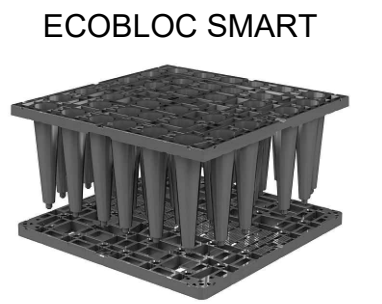

	Ecobloc	Baseplate
Dimensions (mm)	800 x 800 x 330	800 x 800 x 40
Gross Volume	0.211m ³	0.024m ³
Net Volume	0.203m ³	0.021m ³
Material	Polypropylene	Polypropylene
Weight	9.9kg	4.0kg
Void Ratio	>96% depending on number of layers	
Inspectable	Yes	
Comply to load requirements of AS5100. For further information, see installation instructions.		

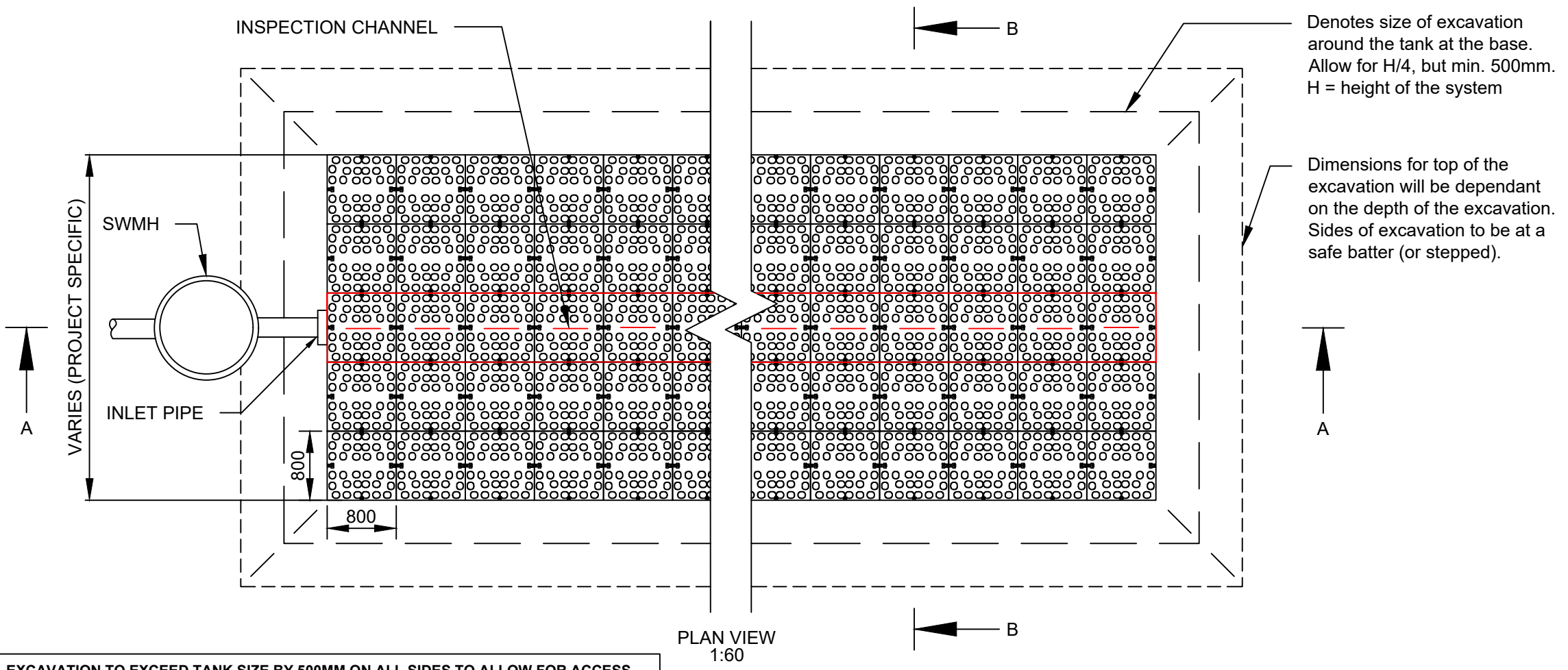

NOTE: EXCAVATION TO EXCEED TANK SIZE BY 500MM ON ALL SIDES TO ALLOW FOR ACCESS

NON-COHESIVE, COMPRESSIBLE GRANULAR MATERIAL (GRAVEL, CRUSHED STONE, SAND, ETC.) *
 MAX. PARTICLE SIZE 63mm
 MIN. FRICTION ANGLE 32°
 MAX. BULK UNIT WEIGHT 20kN/m³
 PERMEABILITY MUST BE AT LEAST CORRESPOND TO THE PERMEABILITY OF THE NATIVE (IN-SITU) SOIL

MIN. 80mm BASE LAYER TO BE GRANULAR MATERIAL (GRAVEL, CRUSHED ROCKS, SAND, ETC.) *
 MAX. PARTICLE SIZE 63mm
 PERMEABILITY MUST BE AT LEAST CORRESPOND TO THE PERMEABILITY OF THE NATIVE (IN-SITU) SOIL

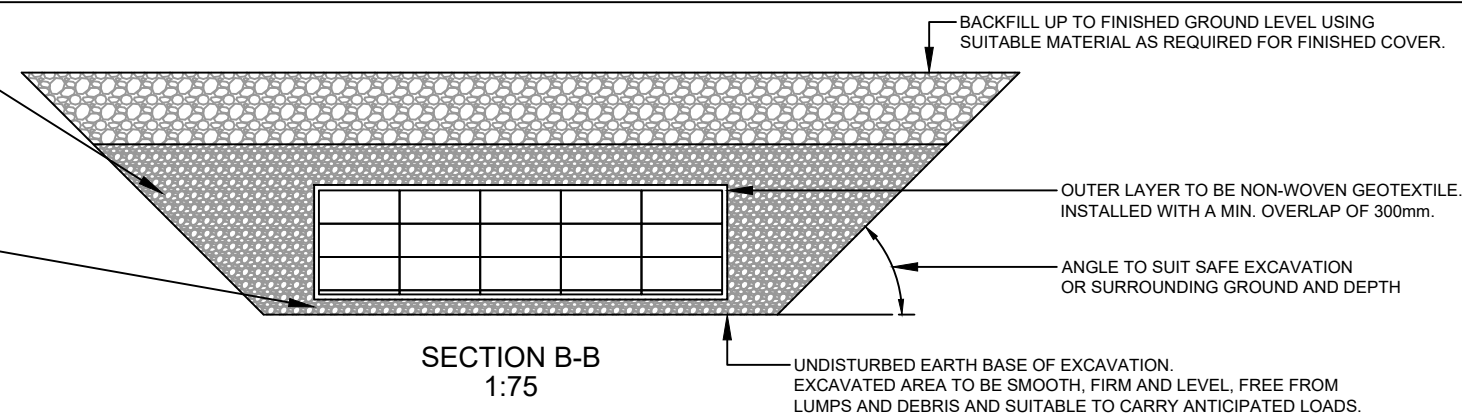

* Cohesive soils (loam/clay, etc.) are NOT suitable backfilling materials. Please contact GRAF Technical Department for more details on installation in cohesive soil conditions.

2		AW	10.09.2024
1		MV	13.09.2022
REV.	DESCRIPTION	BY	DATE

GRAF GRAF Australia Pty Ltd

GRAF Australia Pty Ltd, 43b Sparks Road (rear building), Henderson 6166 WA
 T: +61 1300 131 971 F: +61 8 6499 2688
 E: info@grafaustalia.com.au www.grafaustalia.com.au

DRAWN :	AW	DATE :	10.09.2024
CHECKED :	KH	SCALE :	VARIOUS@A3

PROJECT

GRAF STANDARD DETAILS

DESCRIPTION

INFILTRATION TANK using GRAF ECOBLOC SMART

DRAWING No.	DWG-356	REV.	3 (Pg.1)
-------------	----------------	------	--------------------

THIS DOCUMENT IS SUPPLIED IN STRICT CONFIDENCE AND MUST NOT BE LENT, REPRODUCED OR DISCLOSED TO ANY THIRD PARTY WITHOUT THE WRITTEN CONSENT OF GRAF AUSTRALIA PTY LTD

DO NOT SCALE - IF IN DOUBT ASK

Notice: This drawing is issued only as a guideline and is an estimate of the materials required to construct the drainage system, it should not be used for construction purposes.

Graf Australia Pty Ltd makes no warranty or guarantee in relation to the suitability of any of the layout details shown on this drawing in relation to a particular scheme.

INSTALLATION METHOD:

1. a) Excavate the trench with a safe batter (or stepped) ensuring the footprint allows for sufficient space between tank and the sides (height of the system divided by 4, but at least 500mm around all sides of the tank).
b) Mark out the position of the tank including pipe connections.
c) Lay min. 80mm of single sized non-angular granular material (max. 63 mm) as a base for the tank. This can be laid to a maximum fall of 1%.
2. a) Lay the geotextile over the base of the excavation and up the sides of the trench, overlapping any joins by a minimum of 300mm.
b) The geotextile used must meet the specification stated on the drawing.
3. a) Assemble EcoBloc Smart and Baseplate, position leg ends into corresponding holes in the Baseplate. The bloc will only fit in the correct orientation. Push down firmly to ensure the EcoBloc is located correctly.
b) Install already assembled EcoBloc Smart and Baseplate onto the geotextile until the first layer is complete. Insert retaining clips into each adjacent bloc.
c) To install the next layer of bloc, remove from the stack and turn 90° and position directly above the bloc below. Push down firmly to ensure the bloc is located correctly.
d) Continue until all EcoBloc Smart have been installed, ensuring clips are used to secure each bloc.
e) Fit Endplate to the sides of each bloc by positioning the bottom in place then pushing firmly on the top section.
4. a) Fix adaptor plates to the sides of the bloc in the required position for the pipe connections if required.
b) Cut a hole in the geotextile for pipe connections.
c) Pull geotextile up around the sides and fully wrap the bloc, securing the top in place.
d) Install vent pipe connections into the top layer of the tank and direct to suitable locations.
e) Backfill around the tank in 300mm layer increments using non-cohesive, compressible granular material (gravel, crushed rock, sand, etc. with max. particle size of 63mm). The backfill should be brought up evenly around all sides.
f) It is recommended that stormwater treatment system or pre-filtration is installed upstream of the tank to reduce debris, silt, etc. entering the tank to sustain infiltration performance. These should be regularly maintained.

N.B. Installation method may vary depending on depth of the tank and is project specific. For more information or technical questions, please contact our Technical Department at Graf Australia Pty Ltd.

2		AW	10.09.2024
1		MV	13.09.2022
REV.	DESCRIPTION	BY	DATE

GRAF GRAF Australia Pty Ltd
 GRAF Australia Pty Ltd, 43b Sparks Road (rear building), Henderson 6166 WA
 T: +61 8 6499 2688 F: +61 8 6499 2688
 E: info@grafaustalia.com.au www.grafaustalia.com.au

DRAWN :	AW	DATE :	10.09.2024
CHECKED :	KH	SCALE :	VARIOUS@A3

PROJECT
GRAF STANDARD DETAILS

DESCRIPTION
**INFILTRATION TANK
 using GRAF ECOBLOC SMART**

DRAWING No.	DWG-356	REV.	3 (Pg.2)
-------------	----------------	------	--------------------

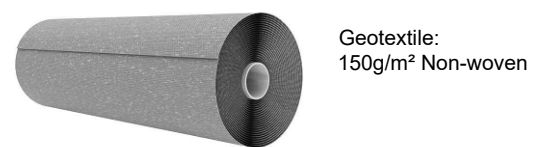
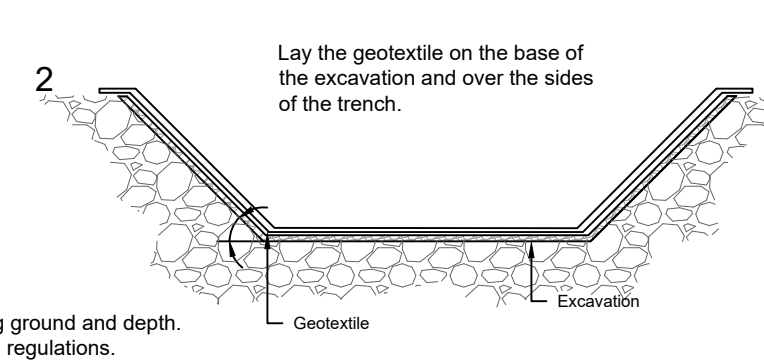
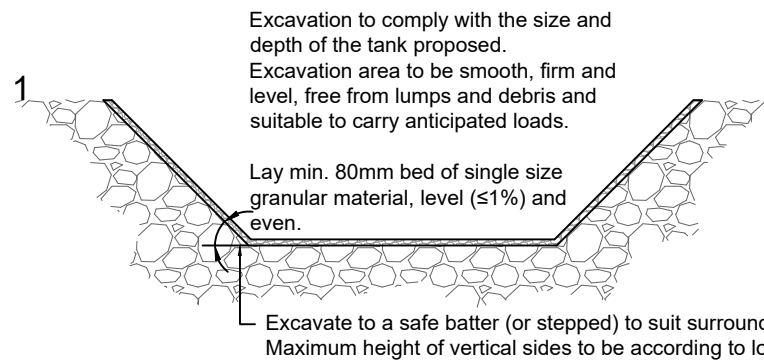

Geotextiles with characteristics less than those specified are unlikely to be suitable and are therefore not recommended for use with Graf Australia systems for this application

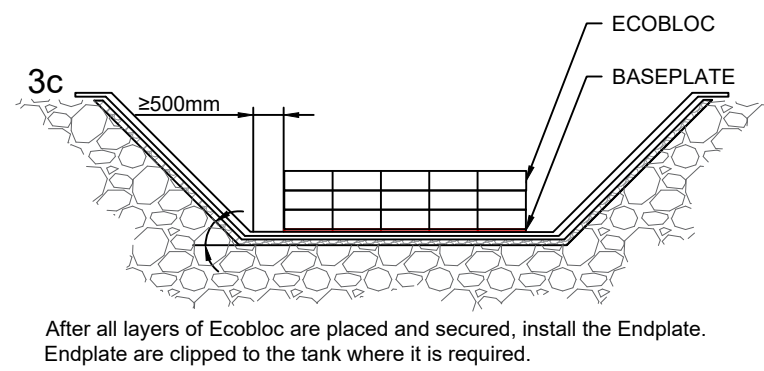
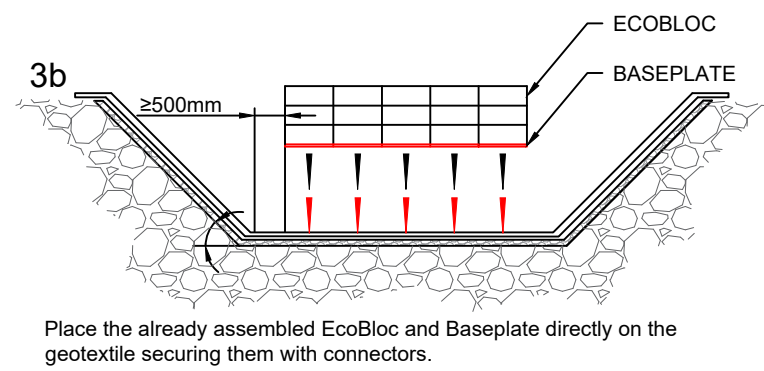
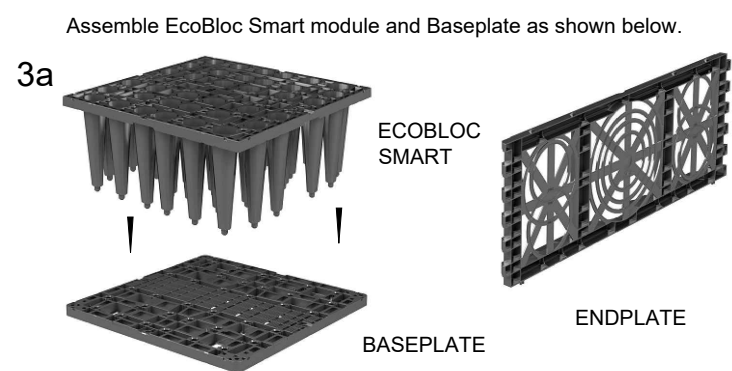

Before installing the next layer, ensure that the connector clips are clipped locking the Ecobloc together.

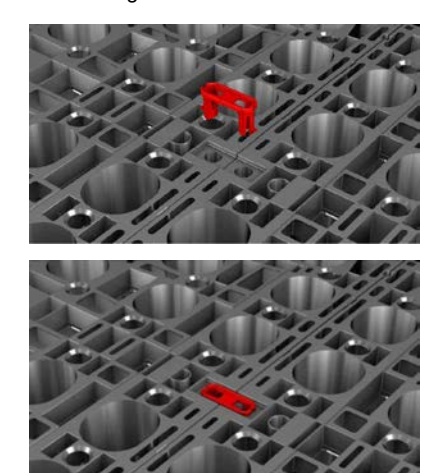

Connector clips are Red for illustration purposes only and are Grey in colour

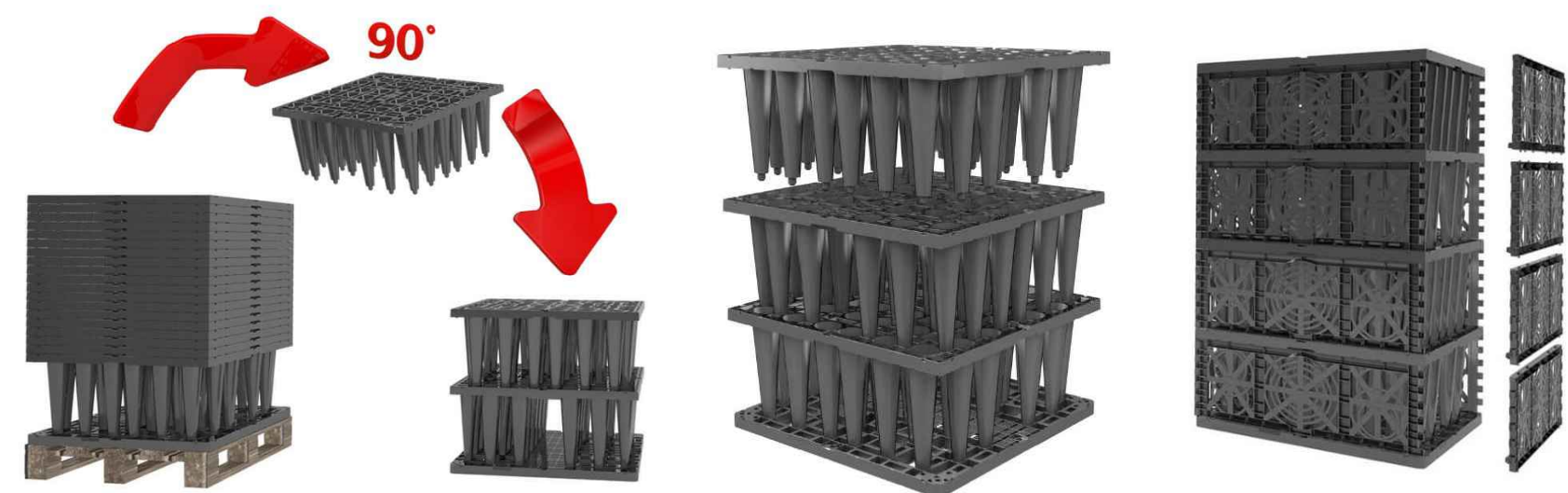

Finally, wrap the blocs with the geotextile.

